



-  **SMONTAGOMME AUTOCARRO**
-  **TRUCK TYRE CHANGERS**
-  **DEMONTE-PNEUS POIDS LOURDS**
-  **DESMONTADORA PARA CAMIONES**



S 960N - 960NT

S 960N

Le dimensioni del mandrino e le corse di lavoro del carrello stallonatore consentono di operare su tutta la gamma di ruote, incluso il tipo super-single. I comandi, con distributori idraulici a leva, permettono di regolare la velocità di movimento.

The operating dimensions of the clamping unit and of the head-tool carriage allow to work on the whole range of wheels, including super-single. The controls, with lever type hydraulic distributors, enable to regulate the speed of the tool holding carriage.

Les dimensions du mandrin et les courses d'exercice du bras de détalonnage permettent d'opérer sur toute la gamme de roues, y compris les roues type "super-single". Les commandes avec distributeurs hydrauliques à levier permettent de régler la vitesse de mouvement.

Las dimensiones del plato y las corridas de trabajo del carro destalonador permiten de trabajar una gama amplísima de ruedas, el tipo super-single incluido. Los mandos, a través de distribuidores hidráulicos de tipo palanca, permiten de regular la velocidad de movimiento.

QUICK MANUAL ROTATION



MINIMUM HEIGHT MINIMUM CLAMPING

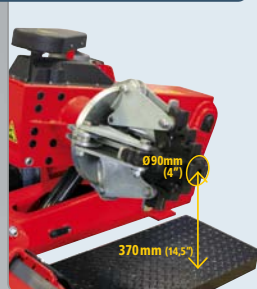

Ideale anche per molte ruote autocarro da 19" e 22,5".
Ideal also for many 19" and 22,5" truck wheels.
 Idéal même pour roues PL de 19" et 22,5".
También para ruedas de camión de 19" y 22,5".

EASY CONTROLS

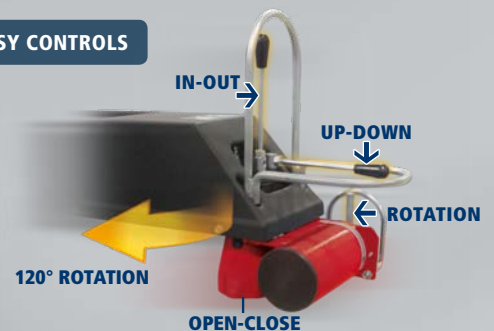

S 960N + VARGNAV11ND 1-5-10 RPM ROTATION SPEED

S 960NT LEVERLESS TYRE CHANGER



STANDARD





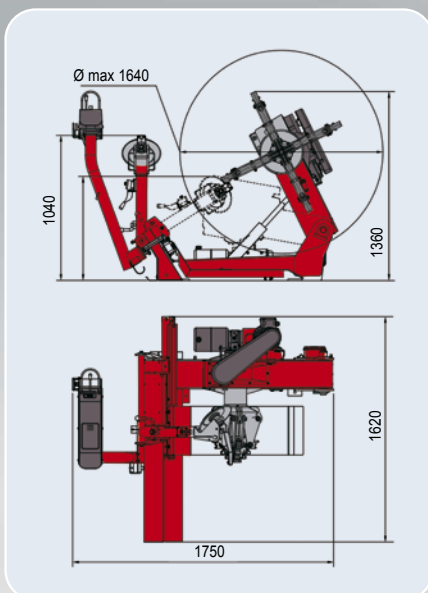

G108A3
 Leva brevettata.
Patented lever.
 Levier breveté.
Palanca patentada.



DATI TECNICI	TECHNICAL DATA	DONNEES TECHNIQUES	DATOS TÉCNICOS	S 960N-NT
Motore rotazione mandrino	Chucking unit rotation motor	Moteur rotation mandrin	Motor rotación plato	2,2 kW
Motore centralina	Hydraulic drive unit motor	Moteur de l'unité de contrôle	Motor centralita	0.75 kW
Opera su cerchi da Ø	Rims Ø	Indiqué pour jantes Ø	Trabaja en llantas de Ø	11"-27"
Ø est. ruota max ammesso	Max. allowed wheel Ø	Ø ext. max. admi pour la roue	Ø maximo exterior de la rueda	1640 mm (64")
Larghezza max ruota	Max. wheel width	Largeur max. de la roue	Ancho maximo de la rueda	925 mm (36.4")
Velocità di rotazione mandrino (giri/min)	Chuck rotation speed (rev/min)	Vitesse de rotation du mandrin (tours/min.)	Velocidad de rotación mandril (rev./min.)	8
Peso	Weight	Poids	Peso	454 kg (1,000lbs)



COMPACT + LIGHT

-  **SMONTAGOMME PER SERVIZIO MOBILE O IN OFFICINA**
-  **TYRE CHANGER FOR ROAD-SIDE AND WORKSHOP SERVICE**
-  **DÉMONTÉ-PNEUS POUR SERVICE MOBILE OU EN ATELIER**
-  **DESMONTADORA PARA SERVICIO MÓVIL O EN EL TALLER**



SRS 926.ST

EASY SETTING

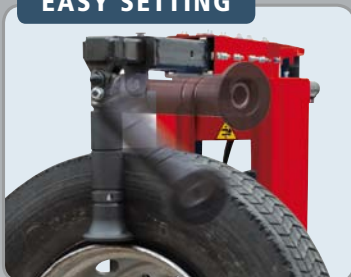

Smontagomme autocarro per servizio mobile o in officina, adatta a furgoni telonati o piccole officine. Comandi su consolle.

Truck tyre changer for both road-side and workshop service, suitable for closed vans and/or small workshops. Controls on consolle.

Démonté-pneus PL pour service mobile ou en atelier. Il adapte aux fourgons bâchés ou pour petits ateliers. Commandes sur console.

Desmontadora para camiones para servicio móvil o para servicio en el taller, ideal para furgonetas o pequeños talleres. Mandos en la consola.

STANDARD

MINIMUM HEIGHT 330MM(13")
HYDRAULIC UP-DOWN MOVEMENT

CENTER LOCKING

Bloccaggio centrale a ghiera
Central docking with ring nut.
Blocage central par flasque.
Bloqueo central a través de platos/conos.

OPTIONS



G108A22
Disc for wheels with lock ring

EASY MOUNTING



EASY DEMOUNTING

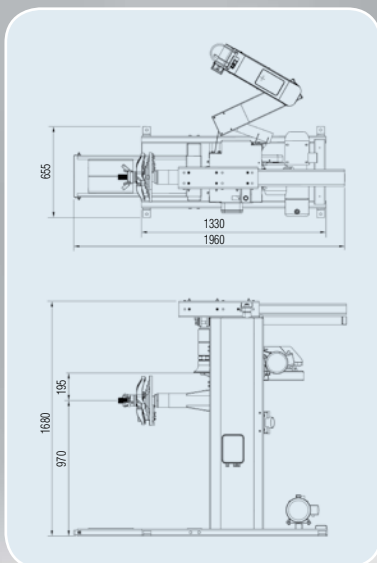

DATI TECNICI	TECHNICAL DATA	DONNEES TECHNIQUES	DATOS TÉCNICOS	SRS926.ST
Motore rotazione mandrino	Chucking unit rotation motor	Moteur rotation mandrin	Motor rotación plato	1,1 kW
Motore centralina	Hydraulic drive unit motor	Moteur de l'unité de contrôle	Motor centralita	2 kW
Ø cerchi	Rims Ø	Ø de la jantes	Ø de llantas en pulgadas	14"-27"
Ø est. ruota ammesso	Max. wheel Ø	Ø de la roue	Ø maximo ext. rueda	1300 mm (51")
Larghezza max. ruota	Max. allowed wheel width	Largeur maxi de la roue	Ancho max. rueda	950 mm (37.4")
Peso	Weight	Poids	Peso	340 kg / 750 lb
Potenza stallonatore	Bead breaker power	Force du détalonneur	Force du détalonneur	16000 N
Peso max ruota	Max wheel weight	Poids maxi de la roue	Poids maxi de la roue	1200 kg / 2645 lbs
Velocità di rotazione mandrino (gir/min)	Chuck rotation speed (rev/min)	Vitesse de rotation du mandrin (tours/min.)	Velocidad de rotación mandril (rev./min.)	8
Coppia max al mandrino	Max. torque to chuck	Couple max. au mandrin	Par máx al mandril	1700 Nm (1253 FtLbs)



Officine Meccaniche Sirio s.r.l. a s.u.

Via Brunelleschi, 9 - 44020 S. Giovanni di Ostellato (Ferrara) - Italy

Sirio Export: Tel. +39-051-6781604 - Fax +39-051-846349 - Sirio Italia: Tel. 0522-647988 - Fax 0522-649760

e-mail: info@sirioequipment.com - www.sirioequipment.com

DSN03U

